

Rotary switches

	Page
Overview	4-2
ON-Off switches, main switches, maintenance switches	4-3
Changeover switches, reversing switches	4-5
(Reversing) star-delta switches	4-6
Multi-Speed Switches	4-7
Interlock circuits	4-11
Single-phase starting switches	4-12
Meter selector switches	4-13
Heater switches	4-14
Step switches	4-15
Rotary switches and switch-disconnectors with ATEX approval	4-17

Rotary switches

Overview

Use and mounting forms

Moeller rotary switches and switch-disconnectors are used as:

- ① Main switches, main switches used as Emergency-Stop devices,
- ② ON-OFF switches,
- ③ Safety switches,
- ④ Changeover switches,
- ⑤ Reversing switches, star-delta switches, multi-speed switches,
- ⑥ Step switches, control switches, coding switches, meter selector switches.

The following mounting forms are available:

- ⑦ Flush mounting,
- ⑧ Centre mounting,
- ⑨ Surface mounting,
- ⑩ Service distribution board mounting,
- ⑪ Rear mounting.

Refer to the latest issue of our Main Catalogue for "Industrial Switchgear".

Other contact arrangements are listed in the K115D/F/GB specialist catalogue (order no. 077643) in addition to the switches listed in the Main Catalogue.

Basic type	ATEX	I_u [A]	Use as						Mounting form				
			①	②	③	④	⑤	⑥	⑦	⑧	⑨	⑩	⑪
TM	–	10	–	×	–	×	–	×	○	○	–	○	–
T0	✓	20	×	×	–	×	×	×	+	○	○	○	+
T3	✓	32	×	×	–	×	×	–	+	○	○	○	+
T5b	✓	63	×	×	×	×	×	–	+	–	○	–	+
T5	✓	100	×	–	×	×	–	–	+	–	○	–	+
T6	–	160	×	–	–	×	–	–	–	–	+	–	+
T8	–	315 ¹⁾	×	–	–	×	–	–	–	–	+	–	+
P1-25	✓	25	×	×	×	–	–	–	+	○	+	○	+
P1-32	✓	32	×	×	×	–	–	–	+	○	+	○	+
P3-63	✓	63	×	×	×	–	–	–	+	–	+	○	+
P3-100	✓	100	×	×	×	–	–	–	+	–	+	○	+
P5-125	–	125	×	×	–	–	–	–	+	–	–	–	+
P5-160	–	160	×	×	–	–	–	–	+	–	–	–	+
P5-250	–	250	×	×	–	–	–	–	+	–	–	–	+
P5-315	–	315	×	×	–	–	–	–	+	–	–	–	+

I_u = max. rated uninterrupted current

1) In enclosed version (surface mounting), max. 275 A.

○ Dependent on the number of contact units, function and contact sequence.

+ Respective of the number of contact units, function and contact sequence.

Rotary switches

ON-Off switches, main switches, maintenance switches

On-Off switches, main switches

T0-2-1
P1-25
P1-32
P3-63
P3-100
P5-125
P5-160
P5-250
P5-315

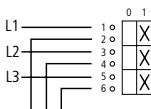

FS 908

Maintenance switches (safety switches) with auxiliary contacts

T0-3-15680



FS 908

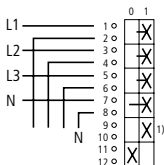

P1-25/.../
P1-32/.../
P3-63/.../
P3-100/.../
...N/NHI11

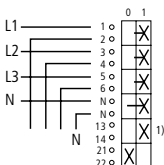

FS 908

1) Load shedding contact

These switches can also be used as switch-disconnectors for lighting, heating or combined loads.

Main switches to IEC/EN 60 204 for rear mounting switches with door interlock, padlocking feature, finger-proof incoming terminals, N and PE terminal, red thumb-grip handle (black, if required), warning label.

If it is not clear which drive is associated with which main switch, an additional maintenance switch is required close to each drive.

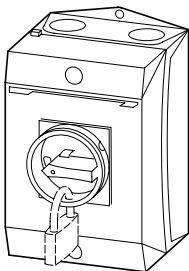

Maintenance switches are fitted to electrical machines or installations to provide safe working conditions in accordance with the safety regulations.

By attaching their own padlock to the SVB padlocking feature, electricians can protect himself against anyone switching on without authorization (→ section "Circuit diagram example for maintenance switches with a load shedding contact and (or) switch position indicator", page 4-4).

Rotary switches

ON-Off switches, main switches, maintenance switches

Circuit diagram example for maintenance T0(3)-3-15683 maintenance switch with a load shedding contact and (or) switch position indicator

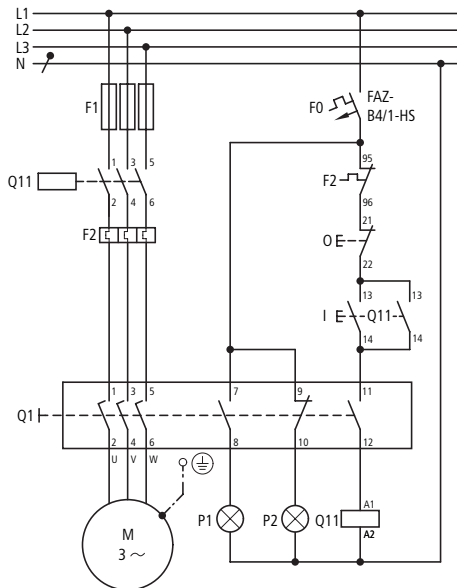

P1: On

P2: Off

Q11: Load shedding

T0(3)-3-15683 circuit diagram

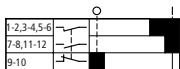

Function

Load shedding: When switching on, the main current contacts close first, then the contactor is activated via the late-make N/O contact. When switching off, the contactor is first disconnected by opening the early-break contact, then the main contacts isolate the motor supply.

Switch position indication:

The position of the switch can be signalled to the control panel or mimic diagram panel via additional make and NC contacts.

Rotary switches

Changeover switches, reversing switches

Changeover switches

T0-3-8212

T3-3-8212

T5B-3-8212

T5-3-8212

T6-3-8212

T8-3-8212



FS 684

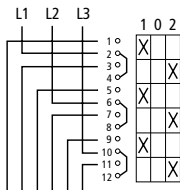

4

Reversing switches

T0-3-8401

T3-3-8401

T5B-3-8401

T5-3-8401



FS 684

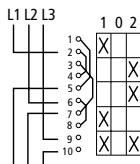

Rotary switches

(Reversing) star-delta switches

Star-delta switches

T0-4-8410

T3-4-8410



FS 635

T5B-4-8410

T5-4-8410

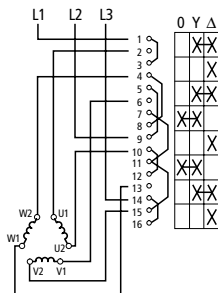

4

Reversing star-delta switches

T0-6-15877

T3-6-15877



FS 638

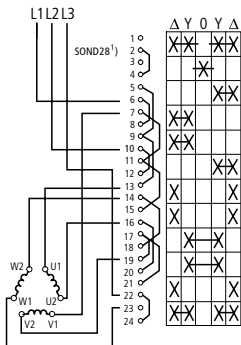

1) Standard contactor interlock → section "Interlock circuits", page 4-11

Rotary switches

Multi-Speed Switches

2 speeds, non-reversing

Tapped winding

T0-4-8440

T3-4-8440

T5B-4-8440

T5-4-8440



FS 644

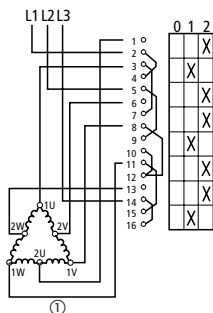

① without connections

2 separate windings

T0-3-8451

T3-3-8451

T5B-3-8451

T5-3-8451



FS 644

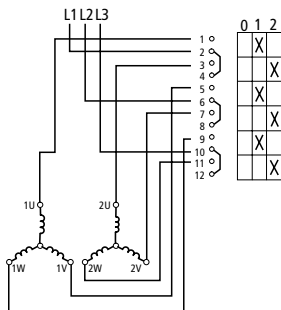

Rotary switches

Multi-Speed Switches

2 speeds, reversing

Tapped winding

T0-6-15866

T3-6-15866



FS 629

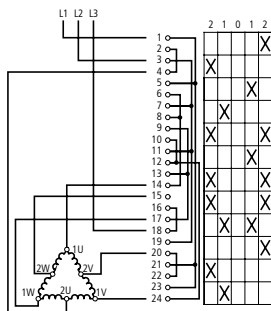

2 separate windings, reversing

T0-5-8453

T3-5-8453



FS 629

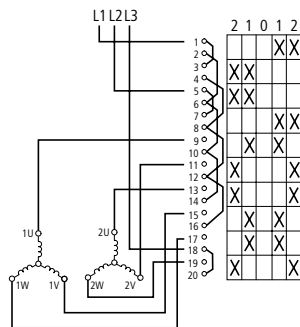

Rotary switches

Multi-Speed Switches

3 speeds, non-reversing

Tapped winding arrangement, single winding for low speed

T0-6-8455

T3-6-8455

T5B-6-8455

T5-6-8455



FS 616

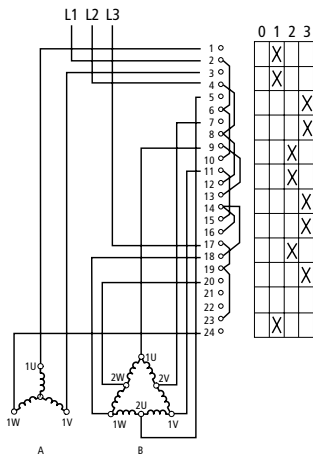

	0	1	2	3
1	X			
2		X		
3	X			
4				
5				X
6				
7				X
8				
9				
10			X	
11				
12			X	
13				
14				X
15				
16				X
17				
18			X	
19				
20				X
21				
22				
23	X			
24				

$$0-(A)Y - (B)\Delta = (B)Y Y$$

Rotary switches

Multi-Speed Switches

3 speeds, non-reversing

Tapped winding arrangement, single winding for high speed

T0-6-8459

T3-6-8459



FS 616

4

T5B-6-8459

T5-6-8459



FS 420

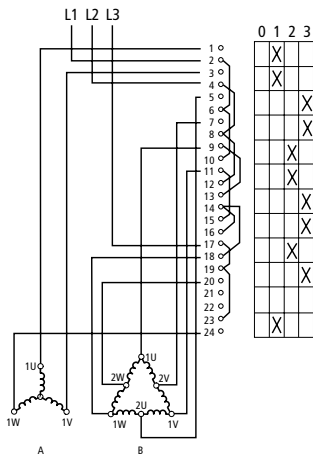

	0	1	2	3
1	X			
2				
3	X			
4				
5				X
6				
7				X
8				
9				
10			X	
11				
12			X	
13				
14				X
15				X
16				X
17			X	
18				
19				X
20				X
21				X
22				
23	X			
24				

0-(B) Δ -(B) Υ Υ -(A) Υ

Rotary switches

Interlock circuits

Interlock circuits between rotary switches and contactors with overload relays provide neat and economical solutions for many switching drive tasks. The following points are common to all interlock circuits:

- Protection against automatic restarting after a motor overload or power failure
- The facility for remote disconnection (e.g. emergency-stop) can be provided by one or more Off pushbuttons.

Without mains disconnection (SOND 27)

Mains disconnection only by contactor primarily for star-delta circuit

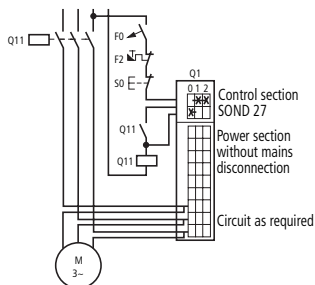

With mains disconnection (SOND 28)

Mains disconnection by contactor and switch

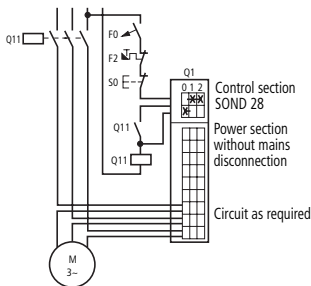

Interlock with contactor (SOND 29)

Contactor can be energized only when switch is in an operating position

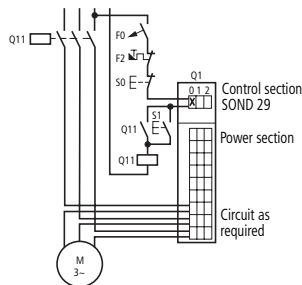

Interlock with contactor (SOND 30)

Contactor can be energized only when switch is in an operating position

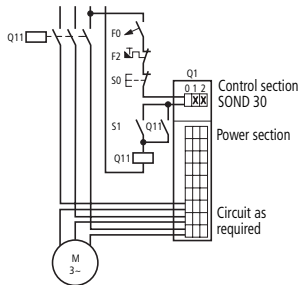

Rotary switches

Single-phase starting switches

Meter selector switches enable you to measure currents, voltages and power in three-phase systems with only one measuring device.

Numerous circuits are possible for the different measurements. Some of the most common ones are shown below.

Voltmeter changeover switch

T0-3-8007

3 × phase to phase

3 × phase to neutral with "0" position

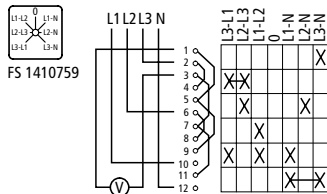

T0-2-15922

3 × phase to neutral without "0" position

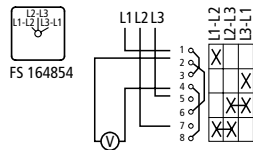

Ammeter selector switches

T0-5-15925

T3-5-15925

For direct measurement

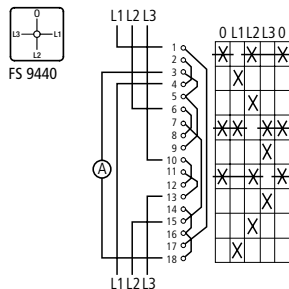

Rotary switches

Meter selector switches

Ammeter changeover switch

T0-3-8048

T3-3-8048

For measurement via transformers, complete rotation possible



FS 9440

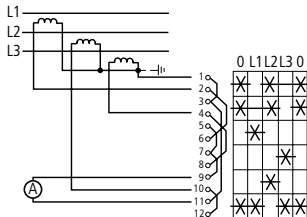

4

Wattmeter selector switches

T0-5-8043

T3-5-8043

Two-phase method (Aron circuit) for three-cable installations loaded as required. The total wattage is calculated by adding together the two wattages.



FS 953

The Aron circuit will give a correct result for four-cable systems only when the sum of the currents equals zero, i.e. only when the four-cable system is balanced.

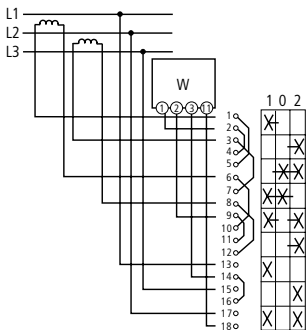

Rotary switches

Heater switches

1-pole disconnection, 3 steps

T0-2-8316

T3-2-8316

T5B-2-8316



FS 420

4

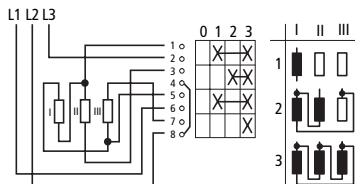

T0-2-15114, complete rotation possible



FS 193840

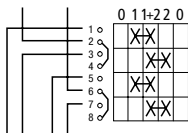

Further heater switches, 2- and 3-pole, with alternative circuitry, output stages, and number of steps are described in the Moeller Main Catalogue, Industrial Switchgear and in the catalogue K 115.

Rotary switches

Step switches

One step closed in each position, complete rotation possible

T0-6-8239

T3-6-8239



FS 301

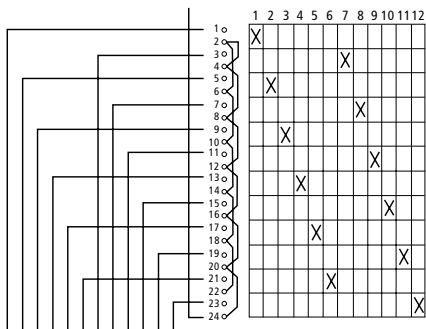

Rotary switches

Step switches

Stay-put switches

On-Off stay-put switch

1-pole: T0-1-15401

2-pole: T0-1-15402

3-pole: T0-2-15403



FS 415



4

Changeover switches

1-pole: T0-1-15421

2-pole: T0-2-15422

3-pole: T0-3-15423



FS 429

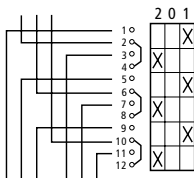

1-pole: T0-1-15431

2-pole: T0-2-15432

3-pole: T0-3-15433



FS 1401

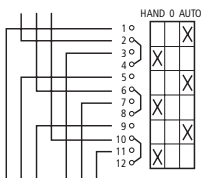

On-Off stay-put switches

1-pole: T0-1-15521

2-pole: T0-2-15522

3-pole: T0-3-15523

With pulsed contact in the intermediate position



FS 908

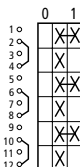

Rotary switches

Rotary switches and switch-disconnectors with ATEX approval

What does ATEX stand for?

ATmosphères EXplosibles = ATEX

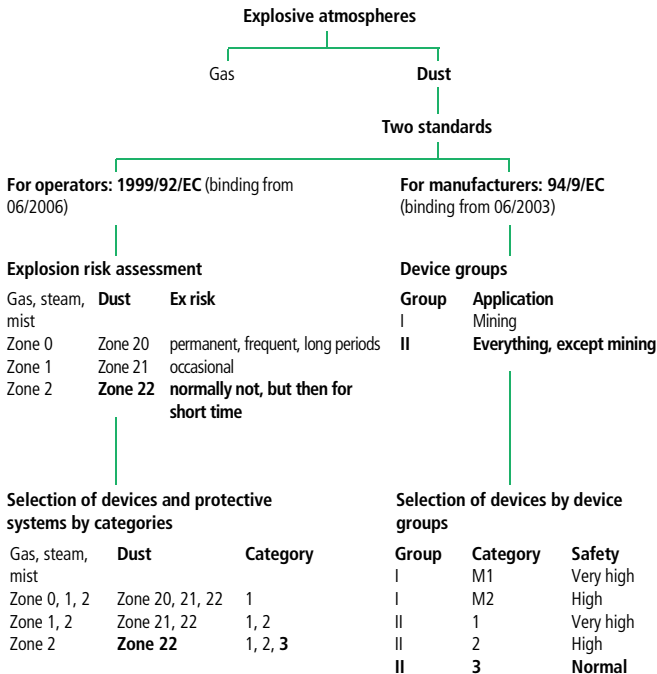

Rotary switches

Rotary switches and switch-disconnectors with ATEX approval

ATEX approval for Moeller

Moeller offers T rotary switches (from 20 to 100 A) and P switch-disconnectors (from 25 to 100 A) in accordance with the binding ATEX Directive 94/6 EC (binding from 06/2006). The switches are provided with the equipment marking Ex II3D IP5X T90°C and are approved for the Ex zone 22 in explosive dust atmospheres.

4

Explosive dust atmospheres are present in:

- Mills,
- Metal polishing workshops,
- Woodworking facilities,
- Cement industry,
- Aluminium industry,
- Animal feed industry,
- Grain storage and preparation,
- Agriculture,
- Pharmacy etc.

The ATEX switches are used as:

- Main switches
- Maintenance switches
- Repair switches,

- ON-OFF switches or,
- Changeover switches.

The following ATEX switches are available:

Current range	T rotary switches	P switch-disconnectors
20 A	T0-.../I1	–
25 A	–	P1-25/I2
32 A	T3-.../I2	P1-32/I2
63 A	T5B-.../I4	P3-63/I4
100 A	T5-.../I5	P3-100/I5

Note

Moeller ATEX switches have passed the EC prototype test for main, maintenance and manual override switches for the current ranges from 20 to 100 A. They are approved for explosive dust atmospheres in accordance with category II 3D, with the test number: BVS 04E 106X.

For further information see installation instructions AWA1150-2141.

General installation and application notes

- Only suitable cable glands may be used for category 3D!
- Use only temperature resistant cables (> 90°C)!
- The maximum surface temperature is 90°C!
- Operation only permissible at an ambient temperature between –20 and +40°C!
- Observe the technical data of the switch used!
- Never open the device in dust explosive atmospheres!
- Observe the requirements of EN 50281-1-2!
- Check that the device is free of dust prior to assembly!
- Do **not** open the device while it is energized!